

PRODUCT SPECIFICATIONS

Each model includes an anchor bolt kit and template.



King Post Mounts

The Skyware Global King Post Mounts are specifically designed for our 96 cm, 1.2 m, 1.8 m and 2.4 m reflectors. Mechanically tested and field proven, these fully adjustable mounts exceed the performance requirements of demanding commercial applications. When assembled and mounted according to the installation instructions provided, these King Post Mounts are engineered to withstand 125 mph winds.

For accuracy and ease of assembly, each mount is accompanied with an anchor pattern template and all necessary installation hardware.

Skyware Global King Post Mounts and hardware are constructed from heavy-gauge steel and are hot-dip galvanized for maximum environmental protection.

SPECIFICATIONS

96 cm, 1.2 m, 1.8 m and 2.4 m King Post Mounts

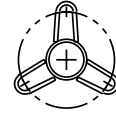
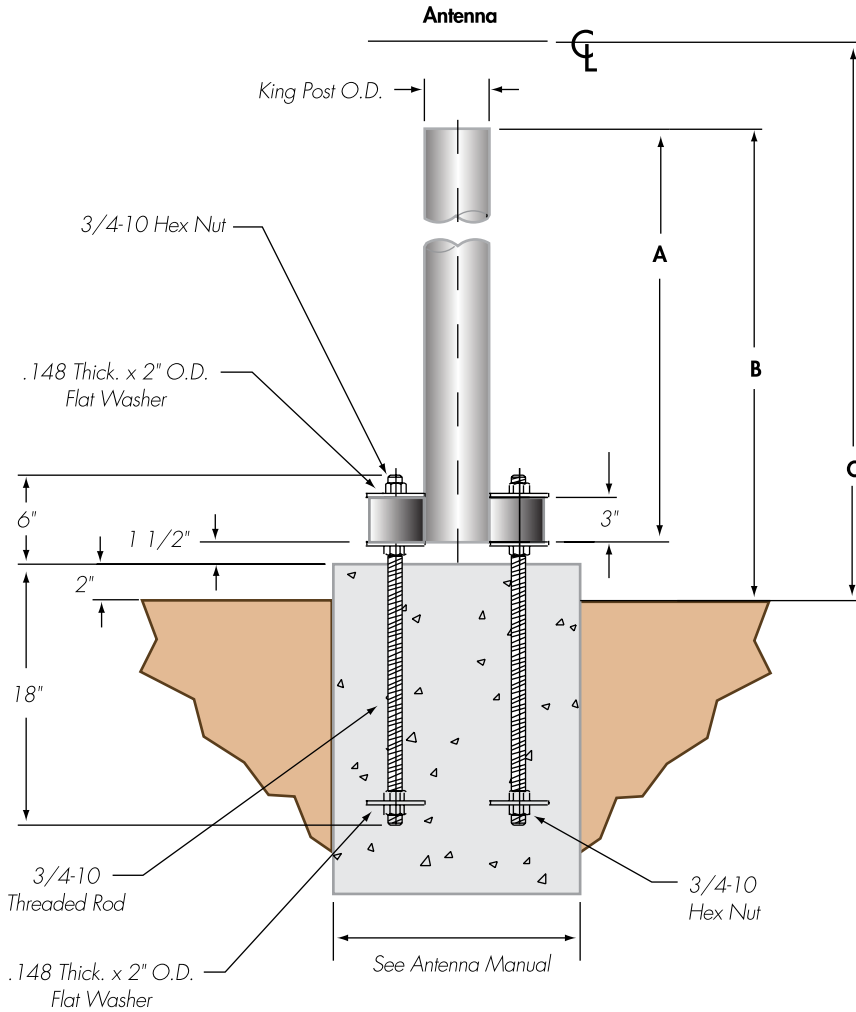

ANCHOR PATTERN

96 cm - 1.2 m
(3) 3/4" Anchors
Equally spaced on 6.80 bolt center

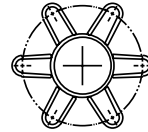

ANCHOR PATTERN 2

1.8 m
(6) 3/4" Anchors
Equally spaced on 8.50 bolt center

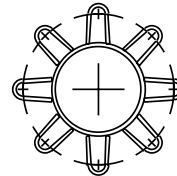

ANCHOR PATTERN 3

2.4 m
(8) 3/4" Anchors
Equally spaced on 10.68 bolt center

Model	Antenna Size	King Post O.D.	Anchor Pattern	Dimensions			Allowable Windspeed	
				A	B	C	Exposure B	Exposure C
610012901	.96m-1.2m	73 mm (2.88")	#1	30.0"	33.5"	40.9"	125 mph	118 mph
610013001	1.8 m	114 mm (4.50")	#2	46.5"	50.0"	55.5"	125 mph	116 mph
610013101	2.4 m	168 mm (6.63")	#3	60.0"	63.5"	69.5"	125 mph	107 mph



Skyware Global
1315 Industrial Park Drive
Smithfield, NC 27577
USA

Telephone: +1-919-989-2280
Sales: salesnc@skywareglobal.com
Internet: www.skywareglobal.com

All designs, specifications and availabilities of products and services presented in this bulletin are subject to change without notice.
VSA-007.2
© 2010 Skyware Global